

STANDARD AND JIGGER
FINISH 400, 405, 425,
445, 450, 460, 470, 2900

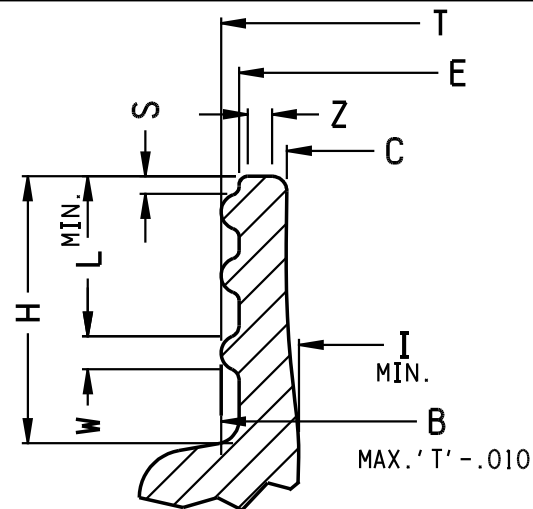

CONCEALED BEAD
FINISH 410, 415

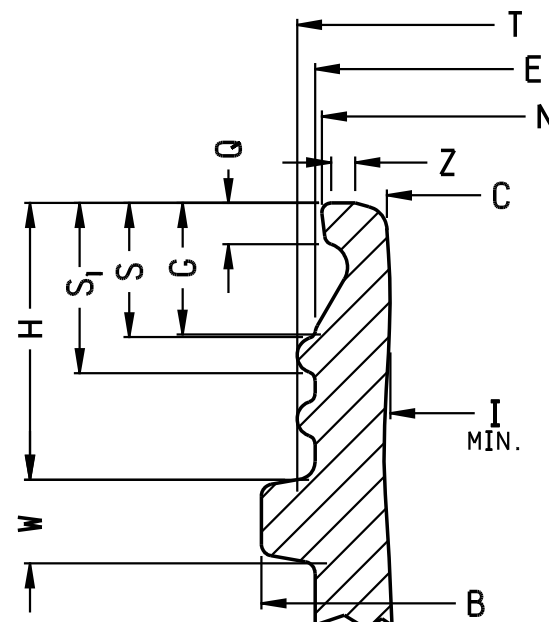

POUR OUT AND SNAP FITMENT
FINISH 430, 435, 480, 485, 490,
495, 455

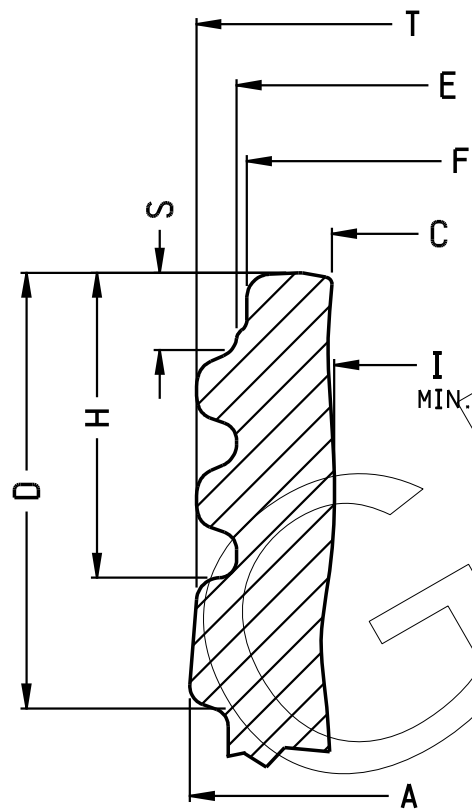

TOP AND SIDE SEAL
FINISH 1650, 1660

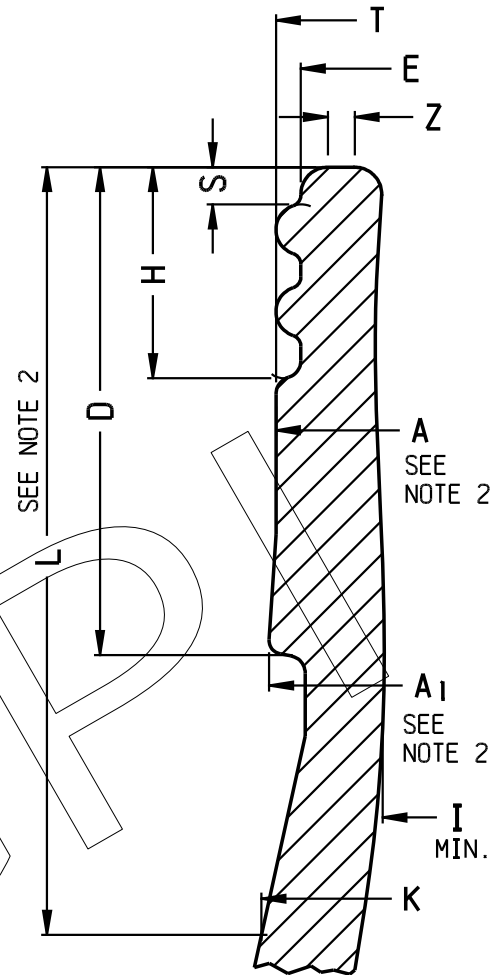

R.O. FINISH COMPATIBLE
WITH A STEL® CAPSULE
FINISH 1680
(SEE NOTE 2)

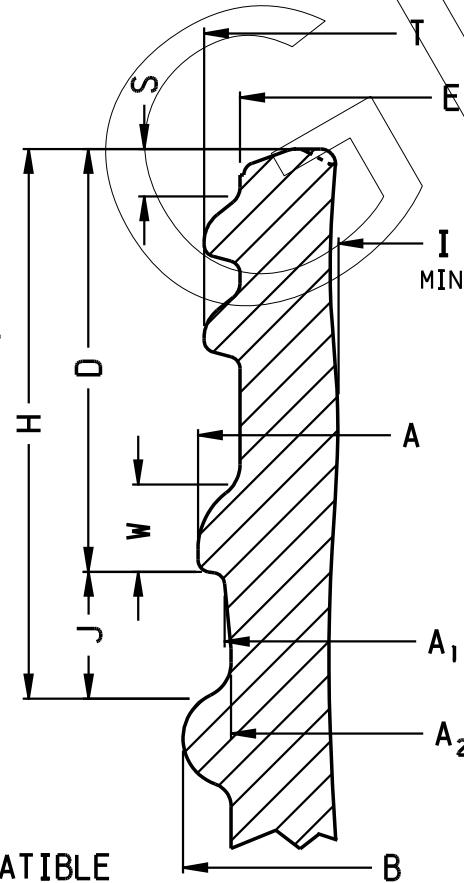

TAMPER EVIDENT
FINISH 350

STANDARD CODE LETTERS

- A. CRIMPING LEDGE (ROLL-ON); TAMPER BEAD (TAMPER EVIDENT) DIAMETER.
- A₁ DIAMETER BELOW THE TAMPER BEAD.
- A₂ DIAMETER BELOW "A₁" JUST ABOVE TRANSFER BEAD.
- B. BEAD DIAMETER.
- C. OPENING CONTROL DIAMETER AT TOP OF FINISH.
- D. CRIMPING LEDGE VERTICAL HEIGHT CONTROL.
- E. WALL DIAMETER AT BASE OF THREAD.
- F. TOP AND SIDE SEAL DIAMETER OR FITMENT RETENTION DIAMETER.
- G. FITMENT CLEARANCE DIMENSION OR POUR LIP CONSTRUCTION DIMENSION FROM TOP OF FINISH.
- H. VERTICAL DIMENSION FROM TOP OF FINISH TO BEAD OR SHOULDER FOR CLOSURE CLEARANCE.
- I. MINIMUM OPENING THROUGH FINISH AND NECK.
- J. VERTICAL BAND DROP DIMENSION.
- K. (FOR USE ON DRAWINGS OF FINISHES COMPATIBLE WITH STEL® CAPSULE ONLY.) CONTROL DIAMETER ON NECK OF CONTAINERS AT BOTTOM OF CAPSULE.
- L. MINIMUM VERTICAL DIMENSION TO TOP OF CONCEALED BEAD FOR CLOSURE THREAD CLEARANCE.
- M. VERTICAL DIMENSION FROM TOP OF FINISH TO SHOULDER FOR JIGGER CLOSURE CLEARANCE (RELATES TO "Y").
- N. LIP DIAMETER FOR POUR OUT OR SNAP FITMENT.
- Q. LIP HEIGHT FOR POUR OUT OR SNAP FITMENT.
- S. VERTICAL DIMENSION FROM TOP OF FINISH TO TOP OF START OF THREAD.
- S₁ VERTICAL DIMENSION FROM TOP OF FINISH TO BOTTOM OF START OF THREAD (PRIMARY USE FOR CLOSURE ORIENTATION).
- T. THREAD DIAMETER.
- U. VERTICAL DIMENSION FROM TOP OF FINISH TO "E" WALL STEP FOR LINER RETENTION. (SEE GPI DRAWING FOR GLASS FINISH NO. 452.)
- W. BEAD WIDTH
- Y. SHOULDER GAUGE DIAMETER FOR JIGGER CLOSURE CLEARANCE. (RELATES TO "M").
- Z. TOP SEALING SURFACE WIDTH.

NOTES

1. SEE INDIVIDUAL DRAWINGS FOR FINISH DETAILS.
2. THE USE OF THE CODE LETTERS "L", "A" AND "A₁" ON THE DRAWINGS FOR FINISHES COMPATIBLE WITH A STEL® CAPSULE IS AN EXCEPTION TO THE STANDARD DEFINITION FOR "L", "A" AND "A₁" AND IS FOR USE ON THESE FINISH DRAWINGS ONLY.

THIS OFFICIAL GLASS PACKAGING INSTITUTE PRINT CONSTITUTES ONE IN A SERIES OF VOLUNTARY STANDARDS INTENDED TO PROVIDE A BASIS FOR ACHIEVING COMPATIBILITY AND INTERCHANGEABILITY BETWEEN MANUFACTURERS AND USERS OF GLASS CONTAINERS AND CLOSURES THEREFOR. THE USER SHOULD BE AWARE THAT OTHER CONTAINER AND CLOSURE DESIGNS MAY DIFFER FROM THIS VOLUNTARY STANDARD, AND IT IS THE USER'S RESPONSIBILITY TO MAKE THE FINAL DETERMINATION AS TO DESIGN AND COMPATIBILITY. GPI ASSUMES NO RESPONSIBILITY FOR EITHER THE USE OF OR INTERPRETATION OF THE STANDARD, FOR IT BEING CURRENT, OR FOR THE DETERMINATION WHETHER ANY PARTICULAR MANUFACTURER'S PRODUCT CONFORMS TO THE STANDARD. THIS DRAWING CONTAINS INFORMATION TAKEN FROM ONE OR MORE PRINTS OF THE GLASS PACKAGING INSTITUTE (GPI). GPI OWNS ALL RIGHT, TITLE AND INTEREST IN THE COPYRIGHTS TO THIS DRAWING AND TO THESE PRINTS. GPI REQUIRES THAT YOU NOT REPRODUCE THIS DRAWING FOR OR DISTRIBUTE THIS DRAWING TO ANY THIRD PARTY WITHOUT GPI'S WRITTEN CONSENT. ANY INQUIRIES OR SUGGESTIONS CONCERNING THIS STANDARD CAN BE ADDRESSED TO THE GLASS PACKAGING INSTITUTE, WASHINGTON D.C. AT WWW.GPI.ORG.

COPYRIGHT © GPI 1994, 1997, 1999, 2001, 2003

Edward A. Grant CHAIRMAN	PRINTED AND DISTRIBUTED AS A VOLUNTARY STANDARD BY GLASS PACKAGING INSTITUTE SUBCOMMITTEE ON DESIGN AND SPECIFICATIONS	APPROVED FOR PUBLICATION 3-19-03	SUPERSEDES DWG. NO. 15
Karl A. Reisig SECRETARY	GLASS FINISH NUMBER 1	GPI DWG. NO. 1-06	
CODE LETTERS FOR C.T. FINISHES			